

Dec. 16, 2008 Pohang APCTP

**Large electric polarization in high pressure synthesized orthorhombic manganites  $\text{RMnO}_3$  (R=Ho,Tm,Yb and Lu) by using the double-wave PE loop measurements**

Yisheng Chai, Y. S. Yang, J. B. Park, N. Manivannan, Y. S. Oh and Kee Hoon Kim

*XMPL, Department of Physics and Astronomy, Seoul National University*

S. M. Feng, L. J. Wang and C. Q. Jin

*Institute of Physics, Chinese Academy of Science, P.O. Box 603, Beijing, China*

# Outline

- ❖ Introduction
- ❖ Double wave method and setup
- ❖ P-E and P-T measurements for  $\text{RMnO}_3$   
(R=Rare earth)

# Introduction

## ❖ Sawyer-Tower circuit for P-E loop measurement

$$C_0 \gg C_x$$

$$V_x = V + V_y \approx V, \quad V/\text{thickness} = E$$

$$V_y = Q/C_0 \quad Q/\text{area} = P$$

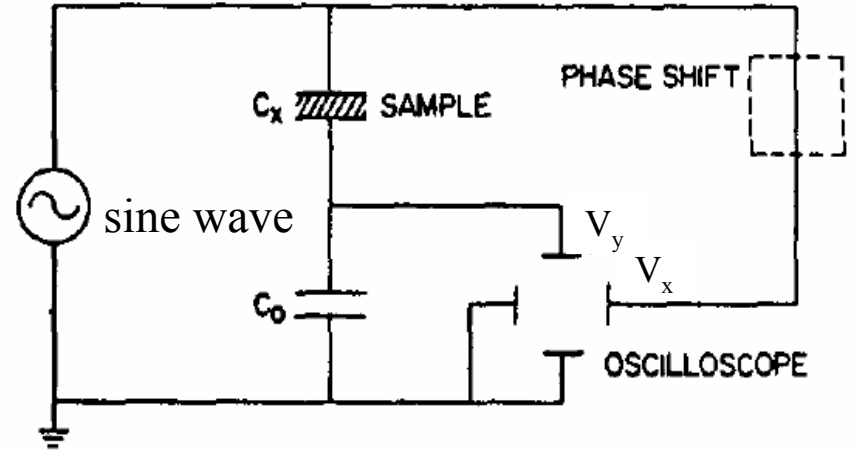

The review of scientific instrument, **28**, 30 (1957)

## ❖ Three components for P-E loop

ferroelectric

capacitive

resistive

typical loop

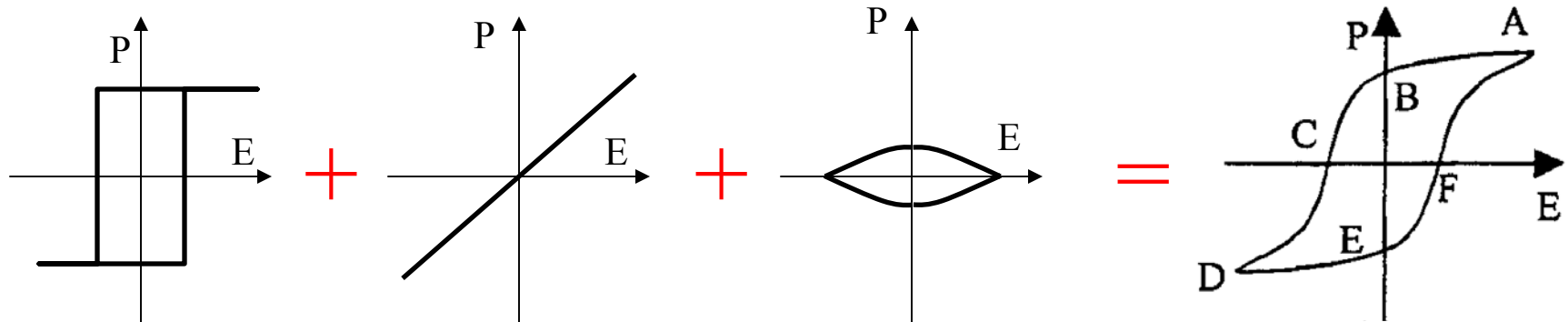

Ferroelectrics, **259**, 55 (2001)

❖  $P(T)$  -- integrate pyroelectric current up to  $T_c$ .

❖ problems:

-- leakage current is large below  $T_c$

~~$P(T)$~~

-- resistivity is low or space charge effect

P-E loop?

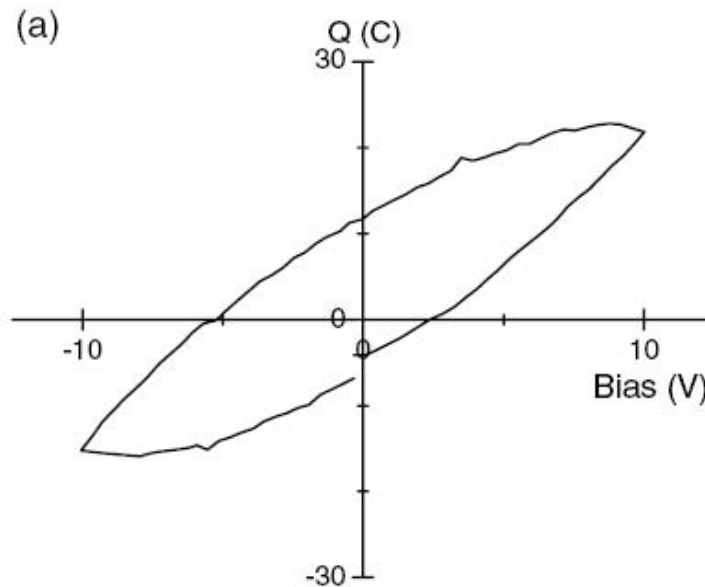

P-E loop of banana, J F Scott, J. Phys.: Condens. Matter **20**, **1** (2008)

❖ New method is needed for samples with leakage!!!

# Double wave method

(M. Fukunaga et al J. Phys. Soc. Jpn. 77, 064706 (2008))

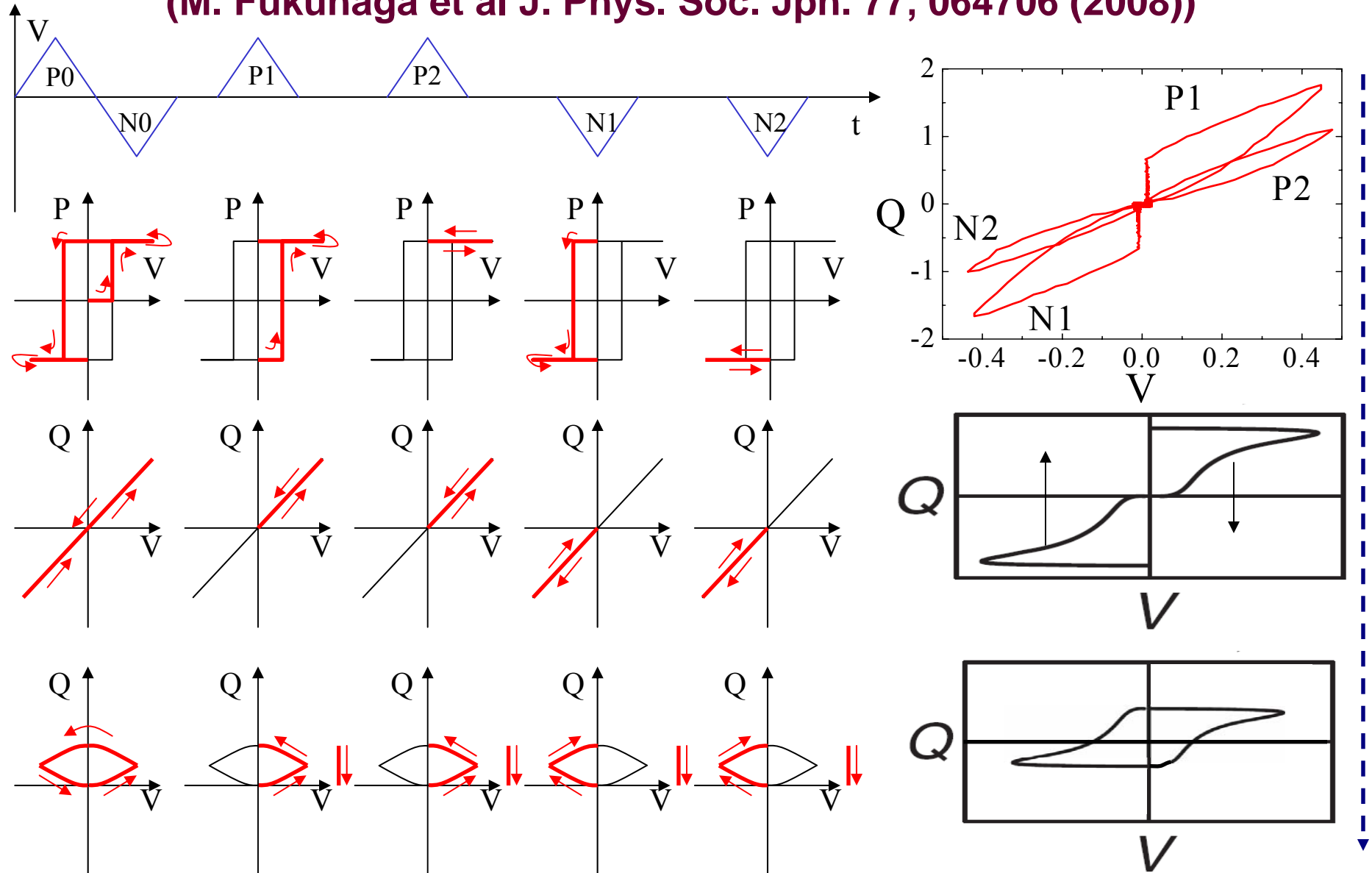

❖ discriminate hysteresis components only

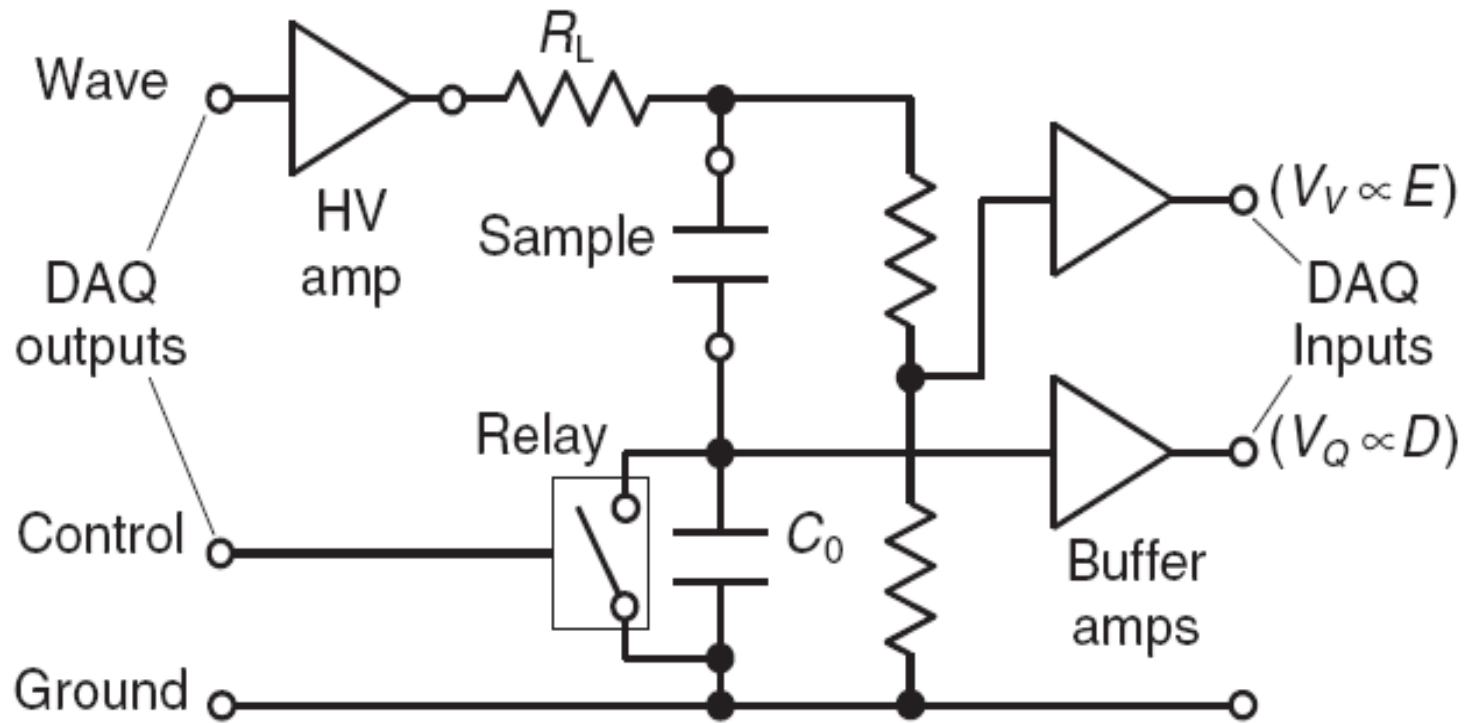

Fig. 5. Schematic diagram of a circuit for the DWM.

*M. Fukunaga et al J. Phys. Soc. Jpn. 77, 064706 (2008)*

## Our setup

-- 20 Hz  $\longrightarrow$  limited  $E$   
 -- sine wave  $\longrightarrow$  variable  $dE/dt$

-- up to 10 kHz  $\longrightarrow$  higher  $E$   
 -- triangular  $\longrightarrow$  constant  $dE/dt$

# Large polarization in orthorhombic $\text{RMnO}_3$

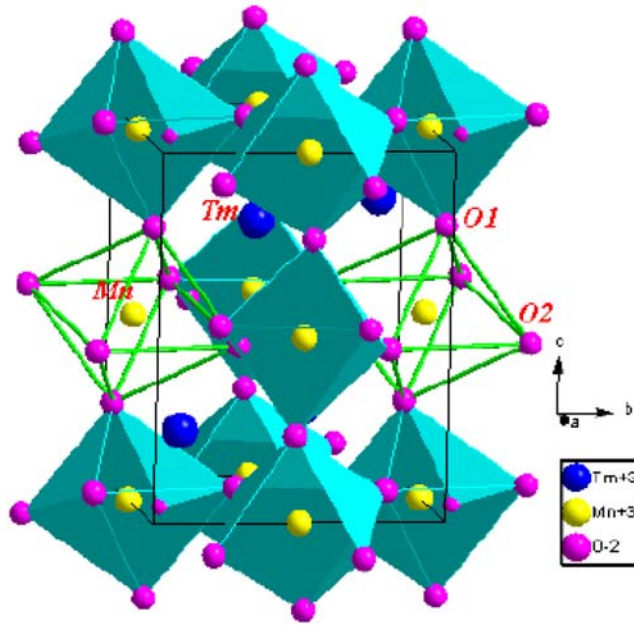

Structure of orthorhombic  $\text{TmMnO}_3$

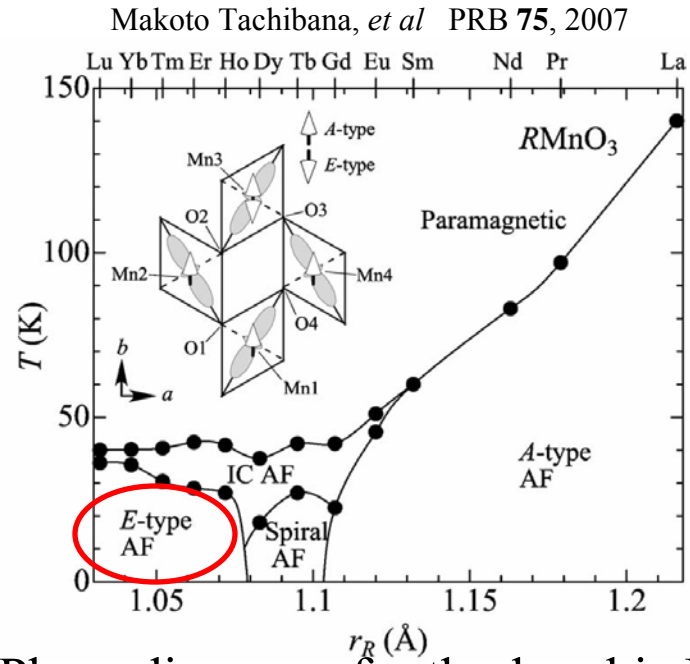

Phase diagram of orthorhombic  $\text{RMnO}_3$

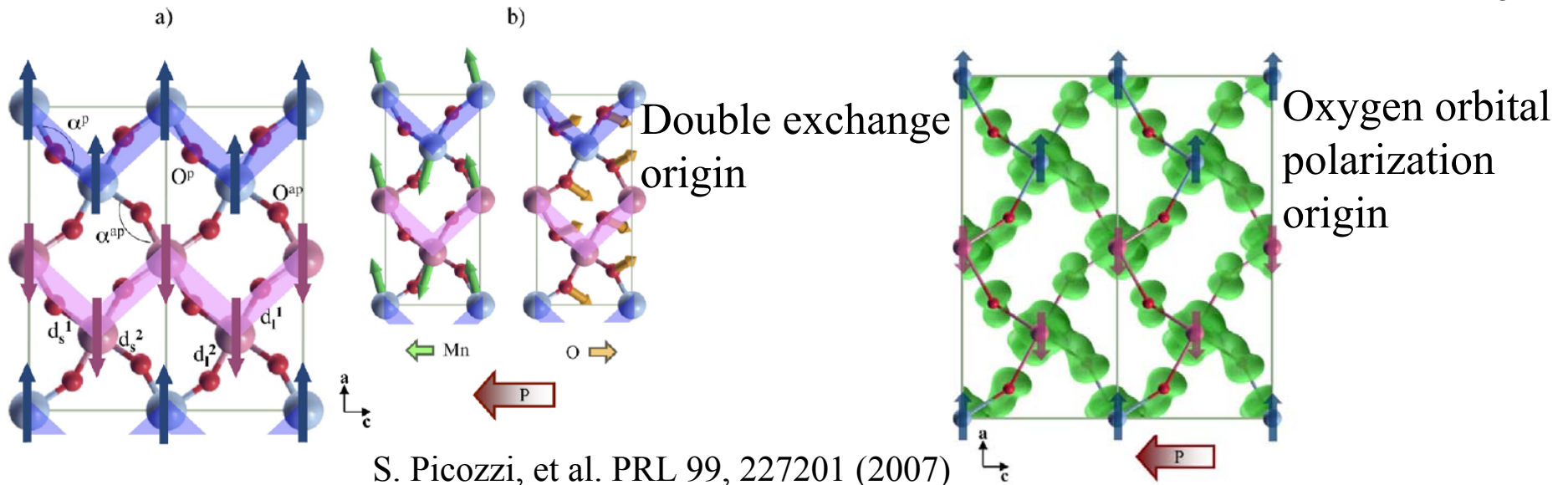

S. Picozzi, *et al*. PRL 99, 227201 (2007)

❖ Although the expected  $P \approx 60000 \mu\text{C}/\text{m}^2$  for  $\text{HoMnO}_3$

S. Picozzi, PRL 99, 227201 (2007)

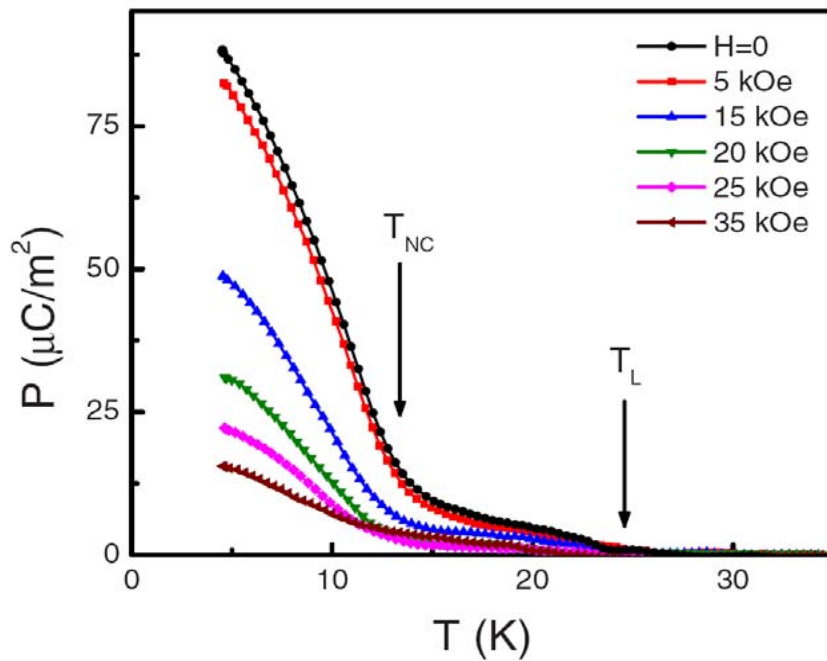

B. Lorenz et al. Phys. Rev. B 76, 104405, 2007

❖ found  $P < 90 \mu\text{C}/\text{m}^2$  in  $\text{HoMnO}_3$

-- small value

-- strongly influenced by Ho spin

❖ Synthesize Lu, Yb, Tm and  $\text{HoMnO}_3$  polycrystals under high pressure

❖ Systematic change of lattice parameters

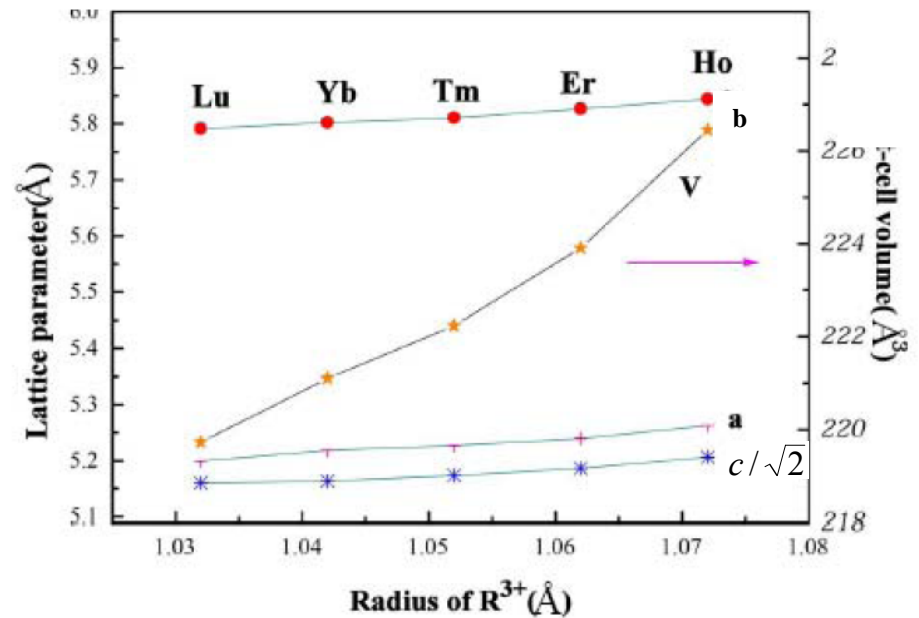

L. J. Wang et al

# P-E and pulse poling of P-T measurements on HoMnO<sub>3</sub>

PE loop measurement procedure

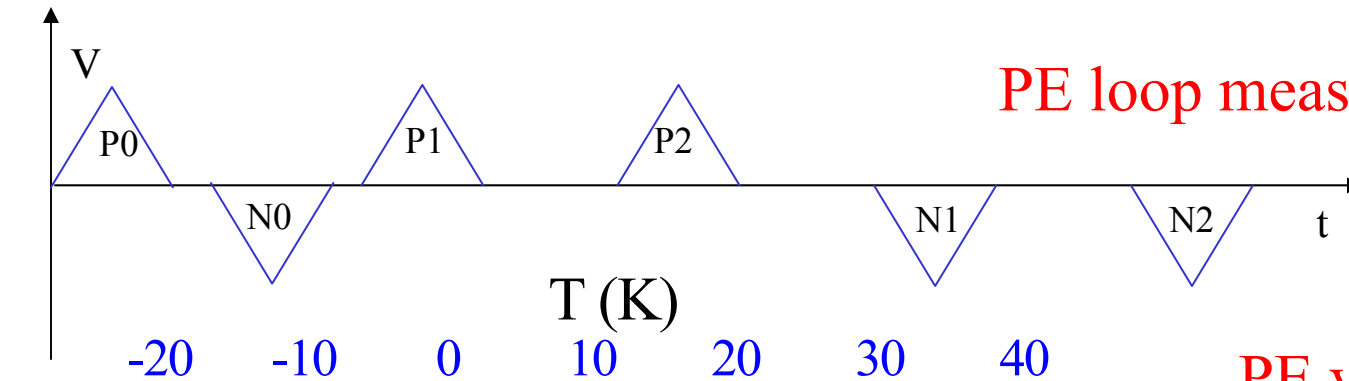

PE vs P(T) at 10 K

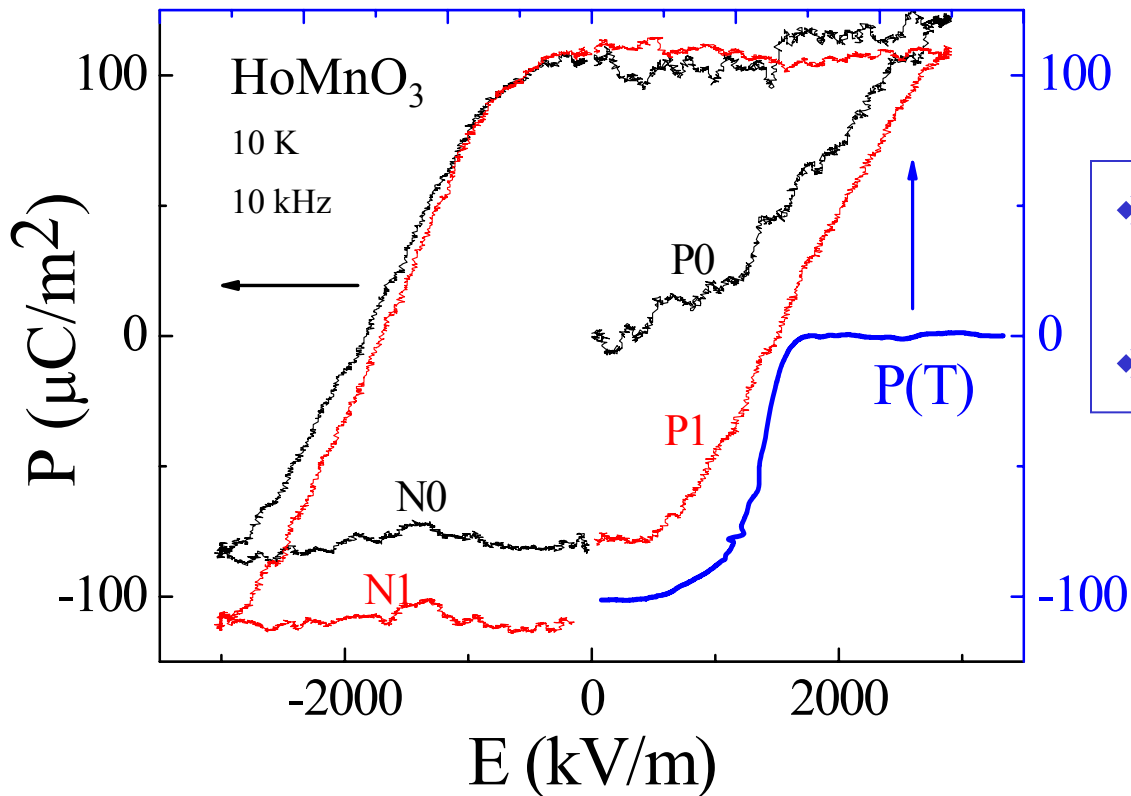

- ❖ PE and P(T) almost match
- ❖ Asymmetry of loops

# thermal history related Polarization in $\text{HoMnO}_3$ and its P-E loops

$\text{HoMnO}_3$  as grown

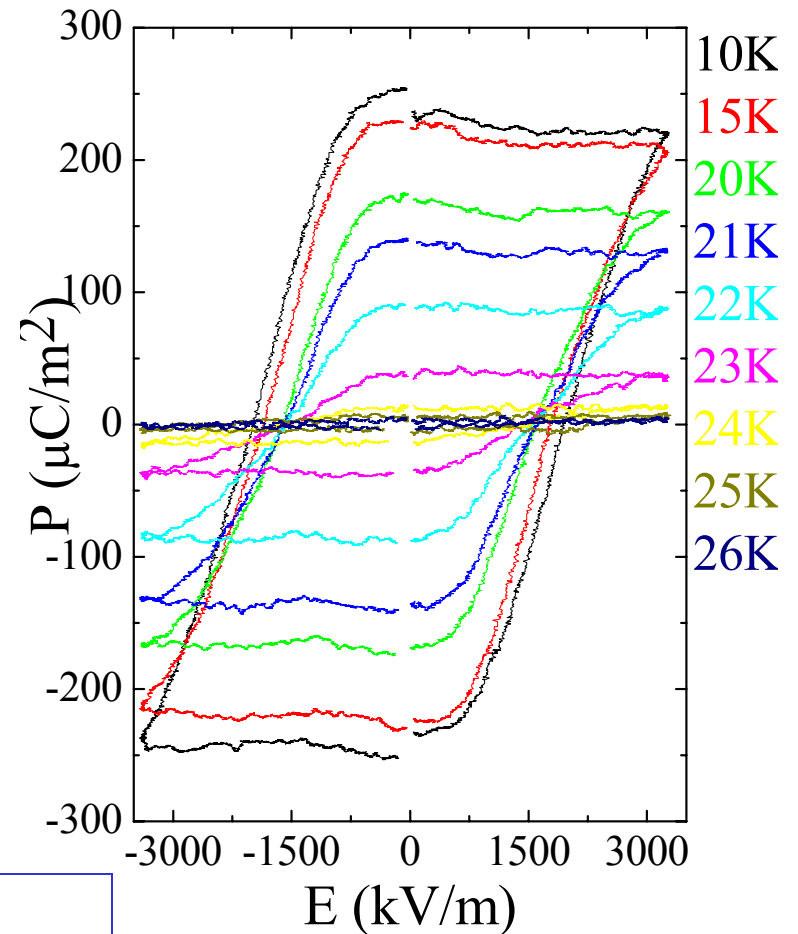
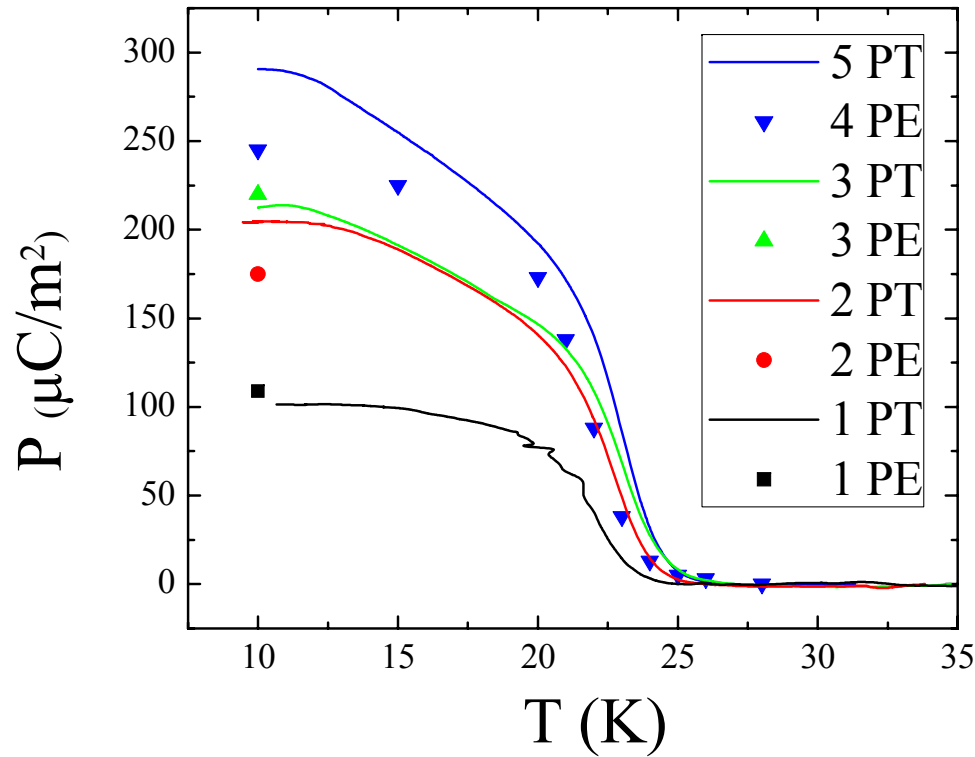

❖  $P=255 \mu\text{C}/\text{m}^2$  at 10K

❖ No large influence to  $P$  by Ho spin

# P-E and pulse poling of P-T measurements on $\text{TmMnO}_3$

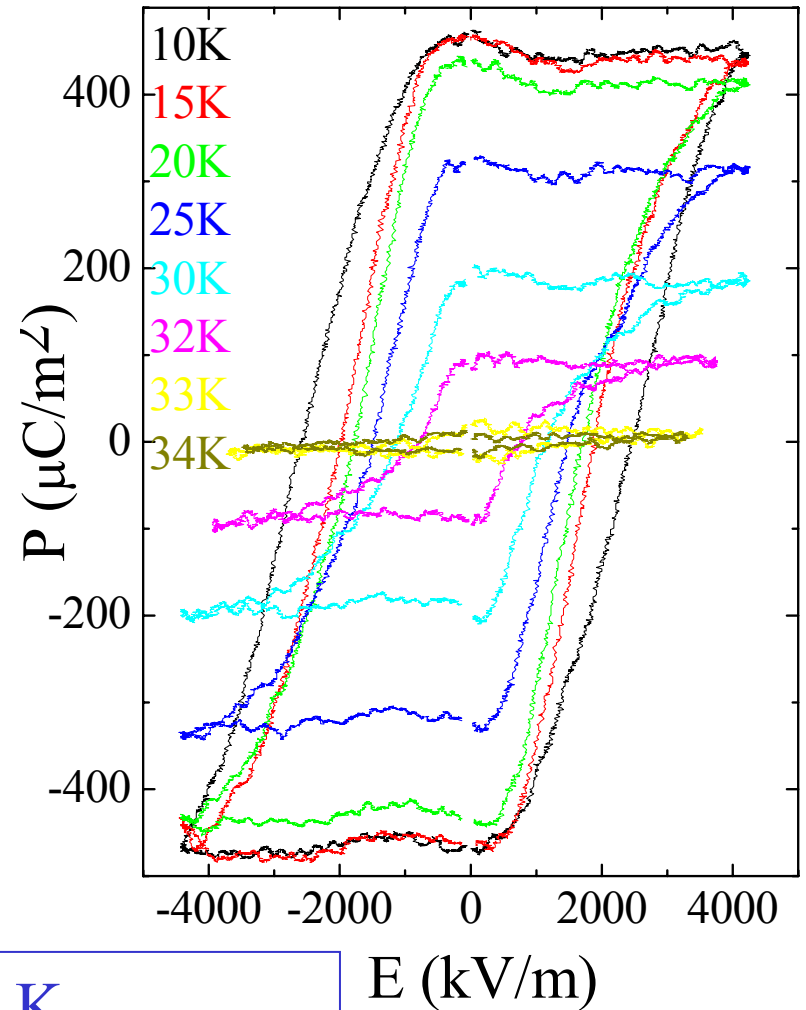
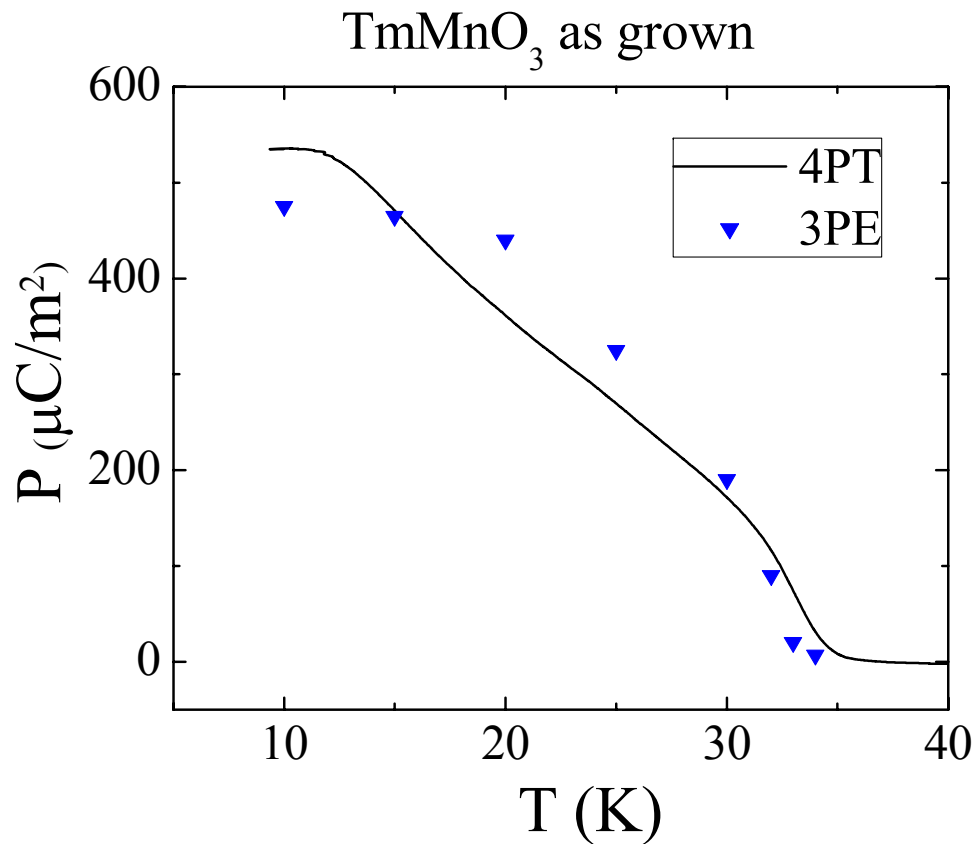

- ❖ PE loops -- fully saturated above 15 K
- ❖ Polarization--should be near  $600\mu\text{C}/\text{m}^2$  at 10 K

# P-E and pulse poling of P-T measurements on $\text{YbMnO}_3$

$\text{YbMnO}_3$  as grown

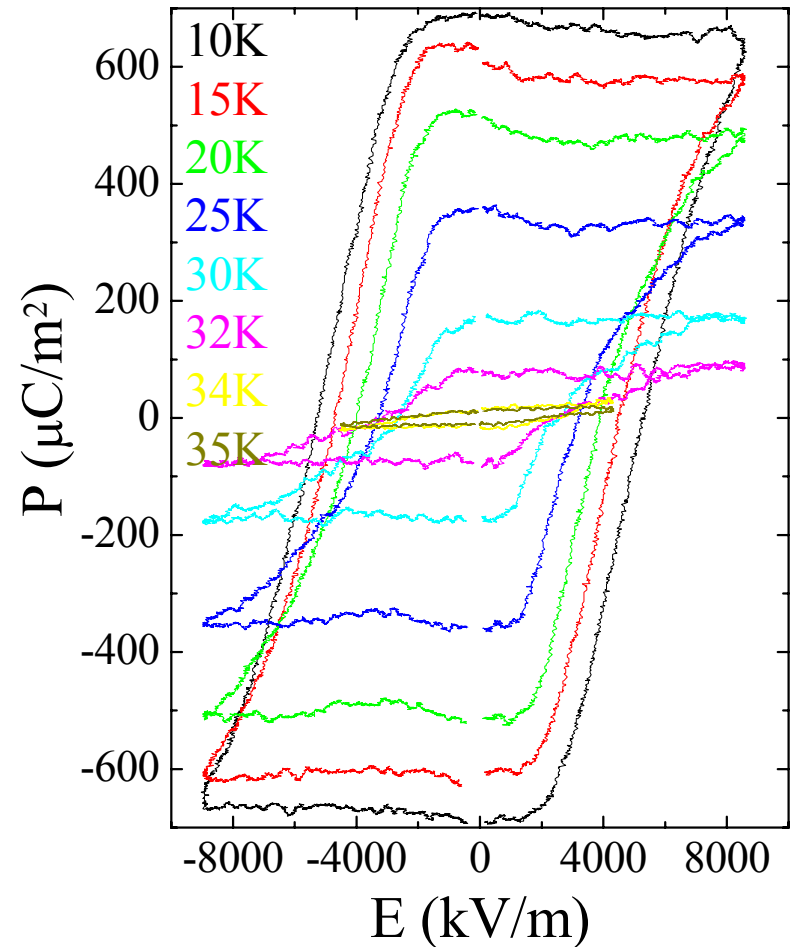
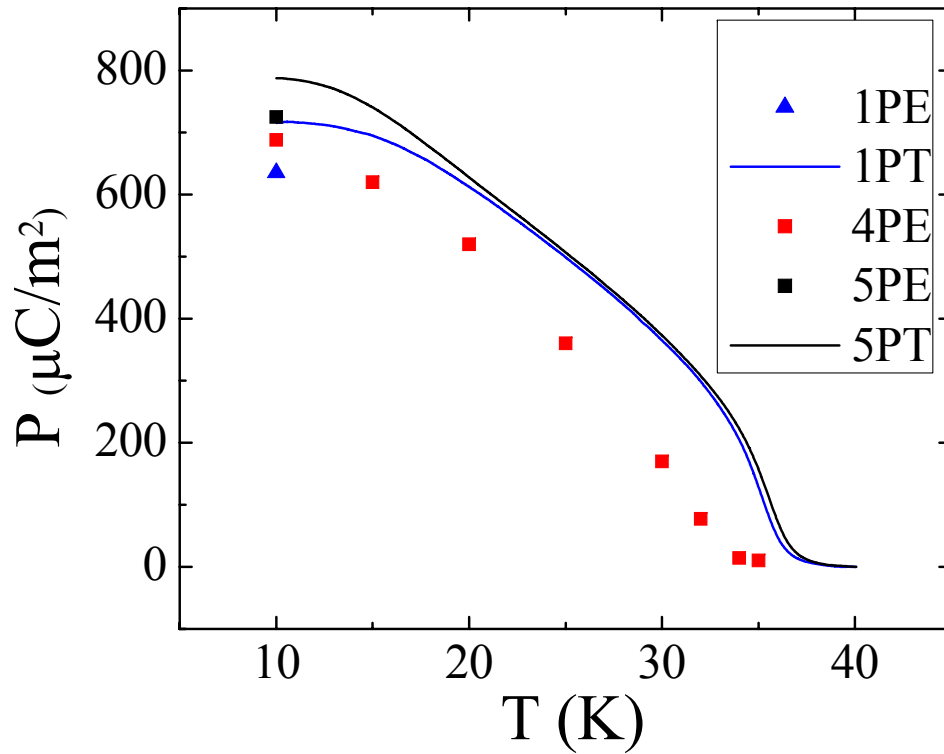

- ❖ slight thermal history effect
- ❖ P close to  $700\mu\text{C}/\text{m}^2$  at 10 K

# P-E and pulse poling of P-T measurements on LuMnO<sub>3</sub>

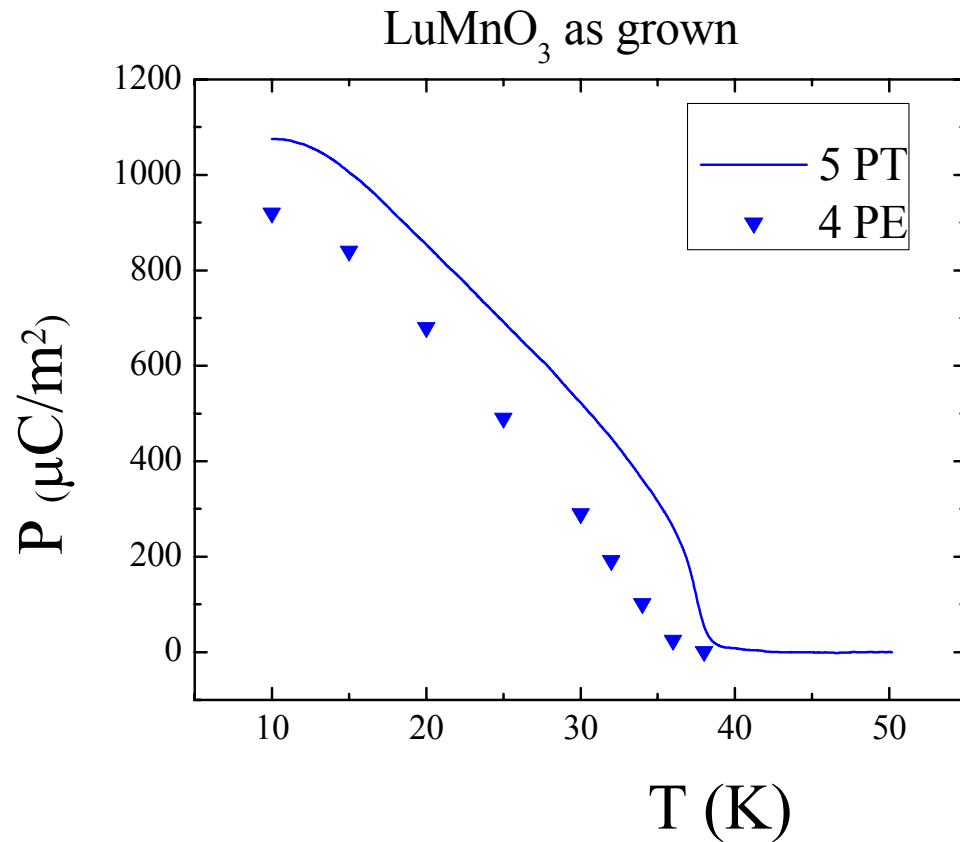

❖  $P = 920\mu\text{C}/\text{m}^2$  at 10 K

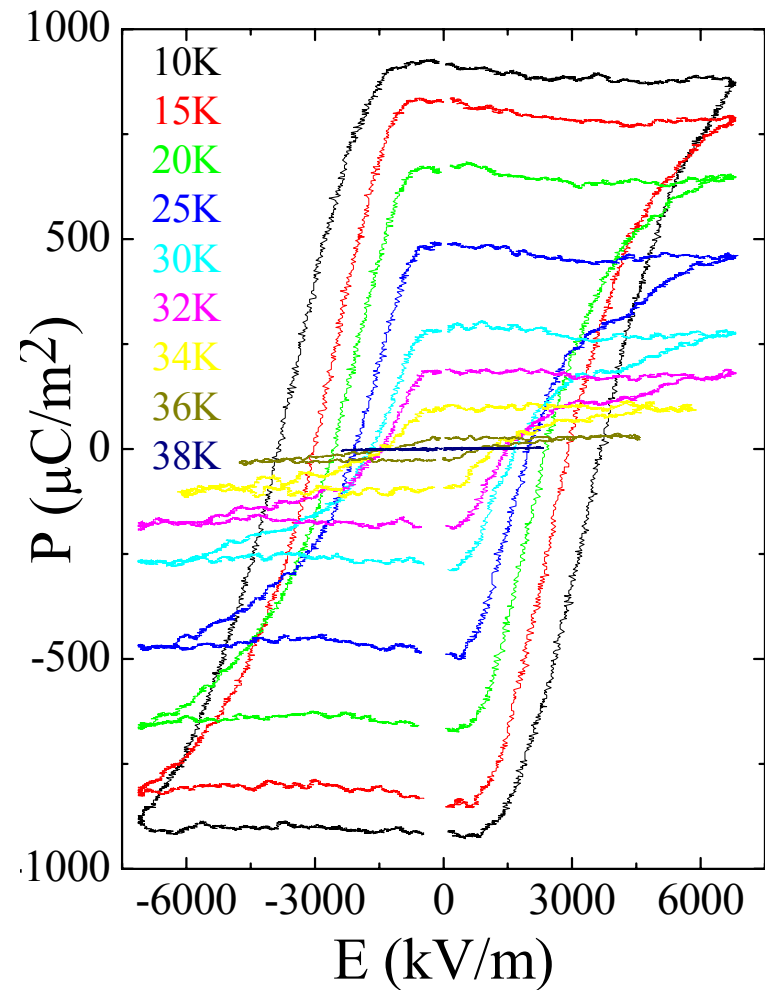

# Polarization and lattice parameters vs. Ion radius

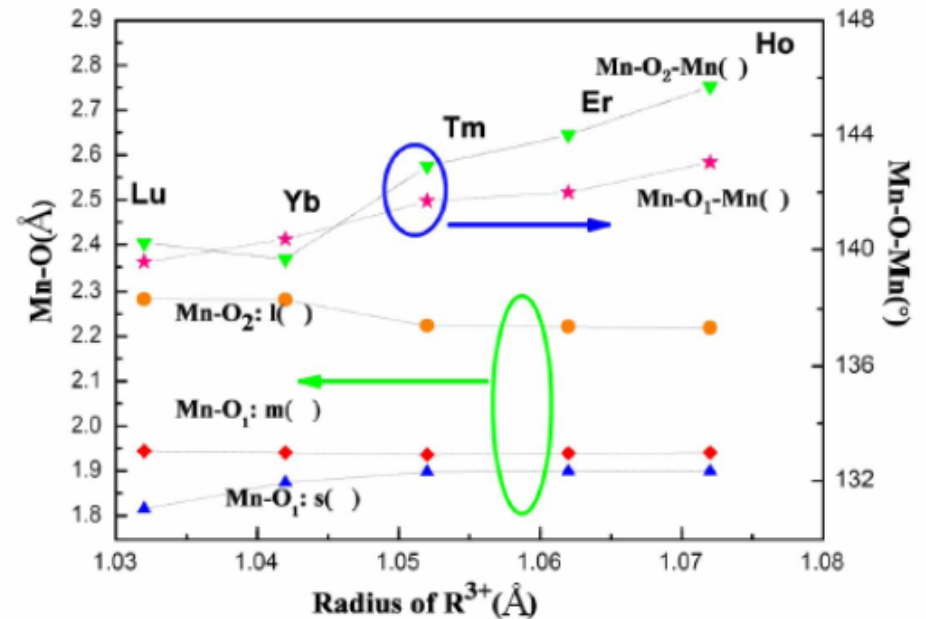
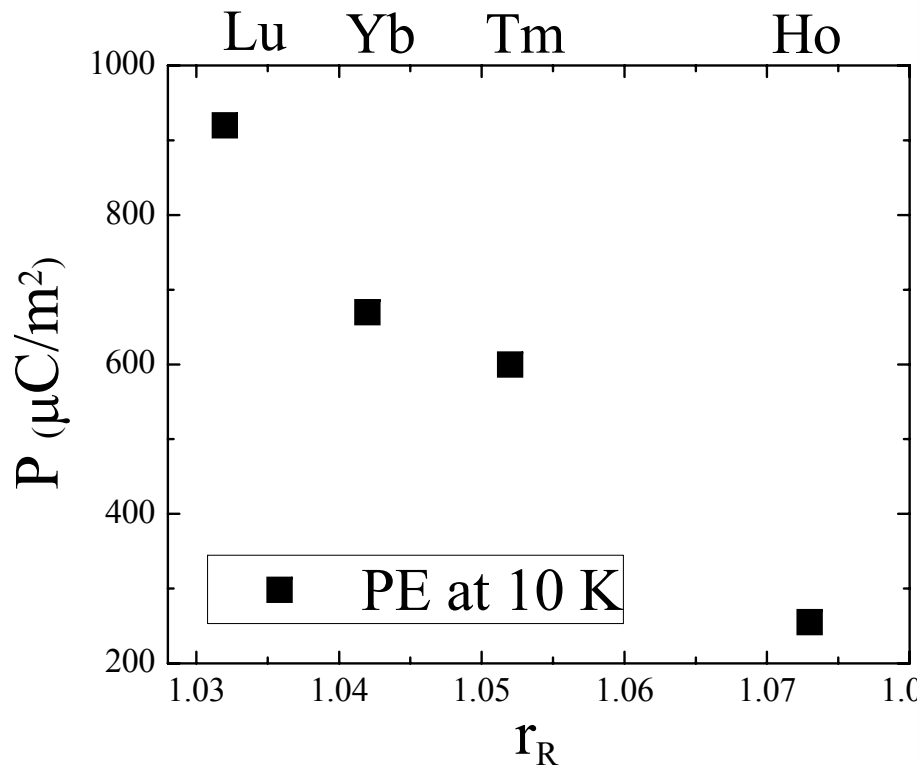

*L. J. Wang et al*

$P$  ↓, the difference between two kinds of Mn-O-Mn angles ↑

contradict with double exchange mechanism

## Discussion

❖ P-E vs pulse poling P-T:

--consistent in all the  $\text{RMnO}_3$  polycrystals

❖ Asymmetry of P-E loops:

--maybe due to oxygen deficiency

❖ change of P is contradicted with the double exchange origin,

--may mainly come from polar charge distribution.

## Conclusion

- ❖ Developed a simple double wave P-E loop measurement system
- ❖ Confirmed large polarization in the E-type AF phase of  $\text{RMnO}_3$  compounds.
- ❖ P maybe mainly due to oxygen orbital polarization contribution.

*Thank you*